

# Tech Rider

- 2 x (IN) XLR DI OUT (1 x bass + 1 x guitar)
- 11 x (IN) XLR MIC (3 x vocal + 8 x drums)
- 4 x (IN) XLR MIC+Phantom (4 x brass)
- 2 x (IN) Klinke/Jack (keyboard r/l stereo)
- 7 x power connections 230V
- 4 x (OUT) MONITOR Box
- 2 x (OUT) MONITOR InEar wireless

**Keyboard** (lef) 

2 x **Klinke/Jack** r/l

3 x **power 230V**

1 x **InEar MONITOR**

# Port Royal



**Drums** (Tibor)

1 x BD, 1 x HH,

3 x Tom, 2 x OH

1 x Snare

**DRUM MONITOR 4**

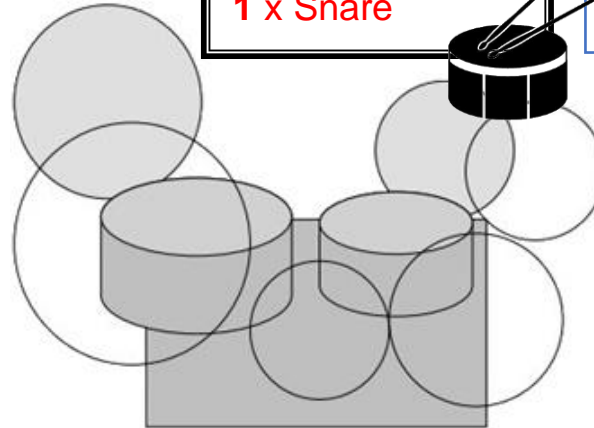

**Bass** (Laza) 

1 x **DI OUT XLR**

2 x **power 230V**



Markbass  
Bass Combo 1x10"

**Guitar** (Jens) 

1 x **DI OUT XLR**

1 x **power 230V**

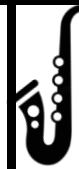
Stereo Röhre 100W  
TOPTEIL + BOX 1x10"

 <b>Trombone</b> (Manfred) 1 x <b>ClipMic</b> <b>XLR+Phantom</b>	 <b>Tenor Sax</b> (Clemens) 1 x <b>ClipMic</b> <b>XLR+Phantom</b>	<b>Main Vocals</b> (Angelo) 1 x <b>power 230V</b> 1 x <b>InEar MONITOR</b>	 <b>Alto Sax</b> (Frank) 1 x <b>ClipMic</b> <b>XLR+Phantom</b>	 <b>Trumpet</b> (Nico) 1 x <b>ClipMic</b> <b>XLR+Phantom</b>
--	--	--	---	---

  
**Vocal Mic 3**  
 (backing: Suse)  

**MONITOR 3**

  
**Vocal Mic 1**  
**main:** Angelo  

**MONITOR 1**

  
**Vocal Mic 2**  
 (backing: Frank+Nico)  

**MONITOR 2**

**Schlagzeug-Grundset, drei Gesangsmikros, Monitoranlage, Kabel und Ständer werden grundsätzlich vom Veranstalter gestellt.**

Port Royal bringt Clipmics für die Bläser, Schlagzeugverschleißteile, Bass- und Gitarrenamp mit.

Alle Änderungen an diesen Bedingungen müssen vorab mit der Band abgesprochen werden.

Port Royal kann gegen eine Aufwandsentschädigung auch weitere Teile der Backline sowie des Schlagzeugs stellen, oder die Anmietung übernehmen.

# Tech Rider **kleine Bühne**

## Minimalkonfiguration

- 7 x (IN) XLR MIC (2 x vocal + 4 x drums + 1 x guitar)
- 4 x (IN) XLR MIC+Phantom (4 x brass)
- 1 x (IN) Klinke/Jack (keyboard mono)
- 5 x power connections 230V
- 2 x (OUT) MONITOR Box

# Port Royal



**Drums** (Tibor)  
1 x BD  
2 x OH  
1 x Snare

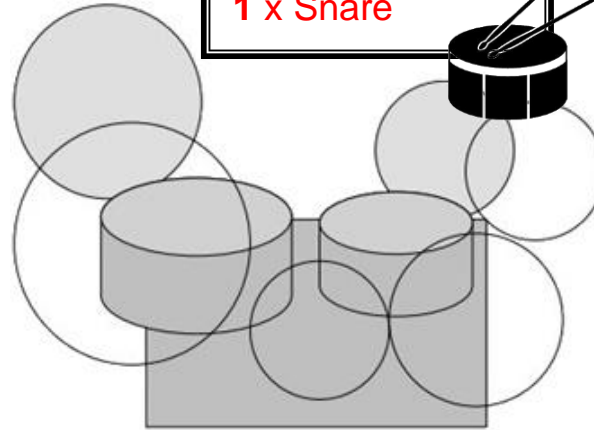

**Keyboard** (lef)  
1 x Klinke/Jack  
2 x power 230V







**Bass** (Laza)  
**ohne Abnahme**  
2 x power 230V  
Nur Backline  
Bass Combo 1x10"



**Guitar** (Jens)  
1 x XLR Mic  
1 x power 230V  
Stereo Röhre 100W  
TOPTEIL + BOX 1x10"



 <b>Trombone</b> (Manfred) 1 x ClipMic XLR+Phantom	 <b>Tenor Sax</b> (Clemens) 1 x ClipMic XLR+Phantom	<b>Main Vocals</b> (Angelo)	 <b>Alto Sax</b> (Frank) 1 x ClipMic XLR+Phantom	 <b>Trumpet</b> (Nico) 1 x ClipMic XLR+Phantom
---	---	-----------------------------	--	--

Vocal  Mic 1  
**main:** Angelo

Vocal  Mic 2  
(backing: Suse+Frank+Nico)

MONITOR 1

MONITOR 2

**Schlagzeug-Grundset, drei Gesangsmikros, Monitoranlage, Kabel und Ständer werden grundsätzlich vom Veranstalter gestellt.**

Port Royal bringt Clipmics für die Bläser, Schlagzeugverschleißteile, Bass- und Gitarrenamp mit.

Alle Änderungen an diesen Bedingungen müssen vorab mit der Band abgesprochen werden.

Port Royal kann gegen eine Aufwandsentschädigung auch weitere Teile der Backline sowie des Schlagzeugs stellen, oder die Anmietung übernehmen.